

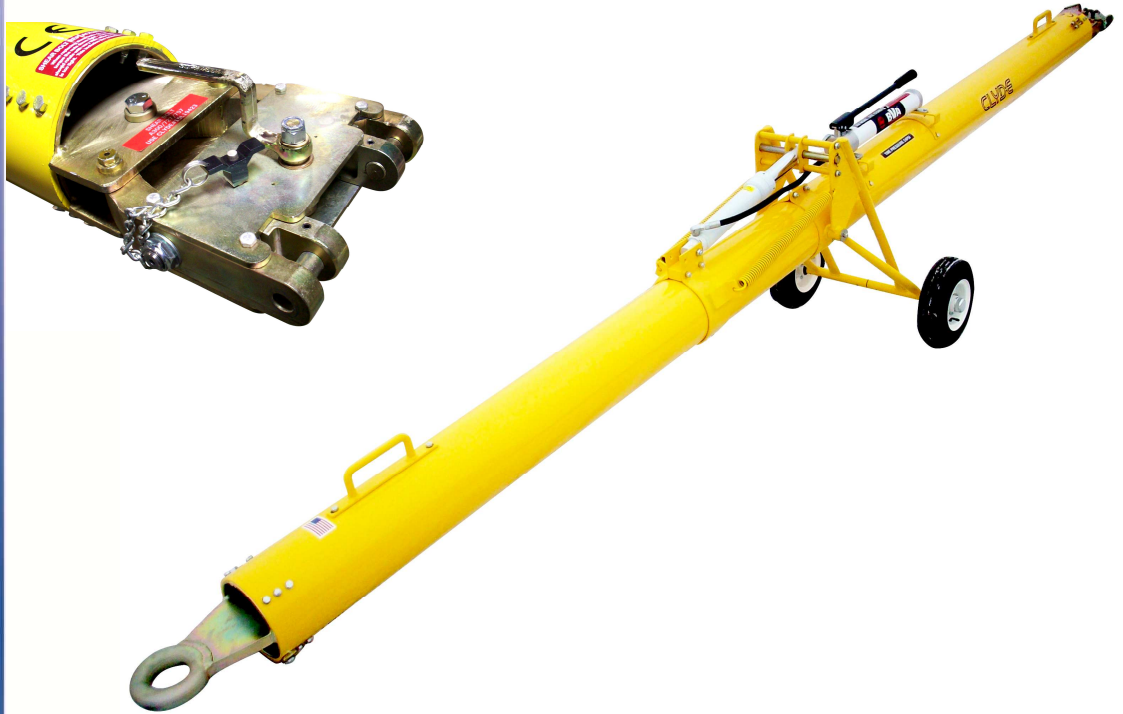

15F146

727 Towbar



Building Quality Ground Support Products Since 1961

- 8" x 15' high strength aluminum tube
- Safety lock system to avoid separation from aircraft
- Fully retractable hydraulic running gear for adjustable height
- Durable powder coat paint
- Extra set of shear bolts included
- Solid tires
- Options:
 - Pin type head
 - 727/707 swivel head available on request
 - Foam filled tires
 - Pneumatic tires
 - Shock mounted lunette

Clyde Machines
P.O. Box 194
1150 Hwy 55 N.
Glenwood, MN 56334 USA
(320) 634-4504
(320) 634-4506 Fax

www.clydemachines.com

CLYDE

15F146

727 Towbar

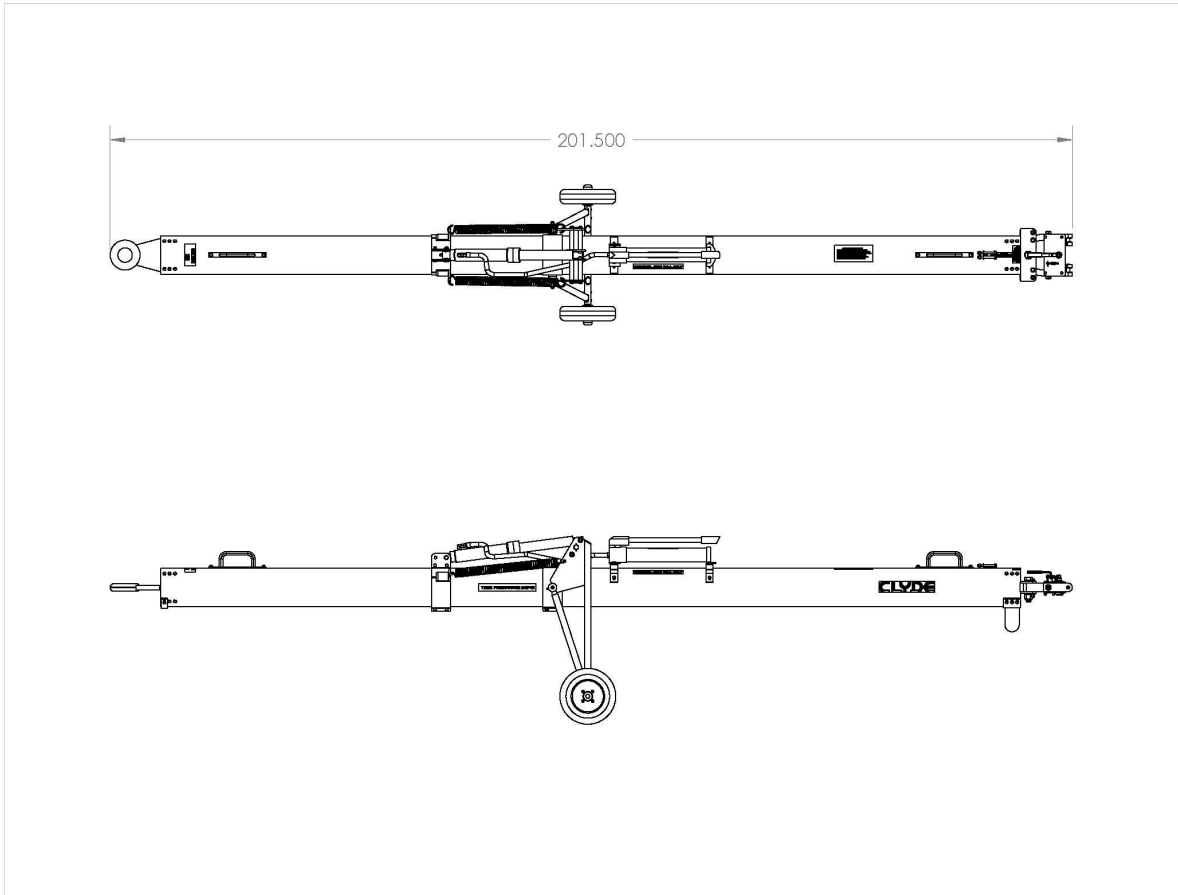

Shipping Information

- Shipping Dimensions:
 - Weight - 325 lbs
 - Length - 205"
 - Width - 29"
 - Height - 25"
- Crated Dimensions:
 - Weight - 720 lbs
 - Length - 217"
 - Width - 26"
 - Height - 27"

CLYDE

Clyde Machines
P.O. Box 194
1150 Hwy 55 N.
Glenwood, MN 56334 USA
(320) 634-4504
(320) 634-4506 Fax

www.clydemachines.com