

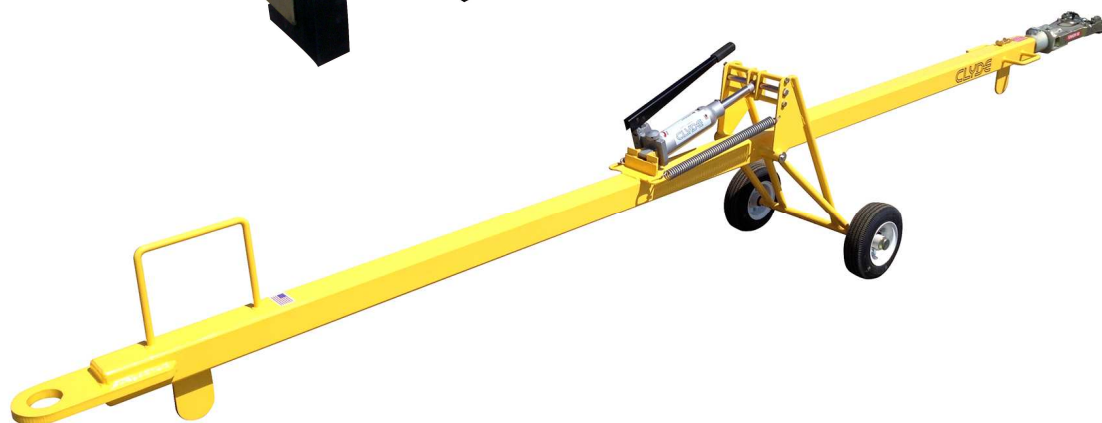

15F2532

# F100/F70 Towbar

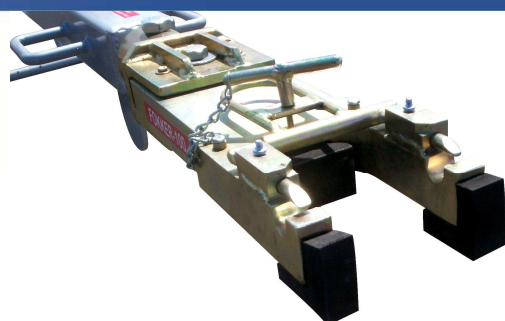

Building Quality Ground Support Products Since 1961

- Main frame constructed of structural tube
- Quality shear bolts for aircraft protection
- Durable powder coat finish
- Extra set of shear bolts included
- Fully retractable hydraulic running gear for adjustable height
- Steel supports on both ends protect head and body from hitting the ground
- Solid tires
- Optional pneumatic tires

# CLYDE

Clyde Machines  
P.O. Box 194  
1150 Hwy 55 N.  
Glenwood, MN 56334 USA  
(320) 634-4504  
(320) 634-4506 Fax

[www.clydemachines.com](http://www.clydemachines.com)

**15F2532**

# F100/F70 Towbar

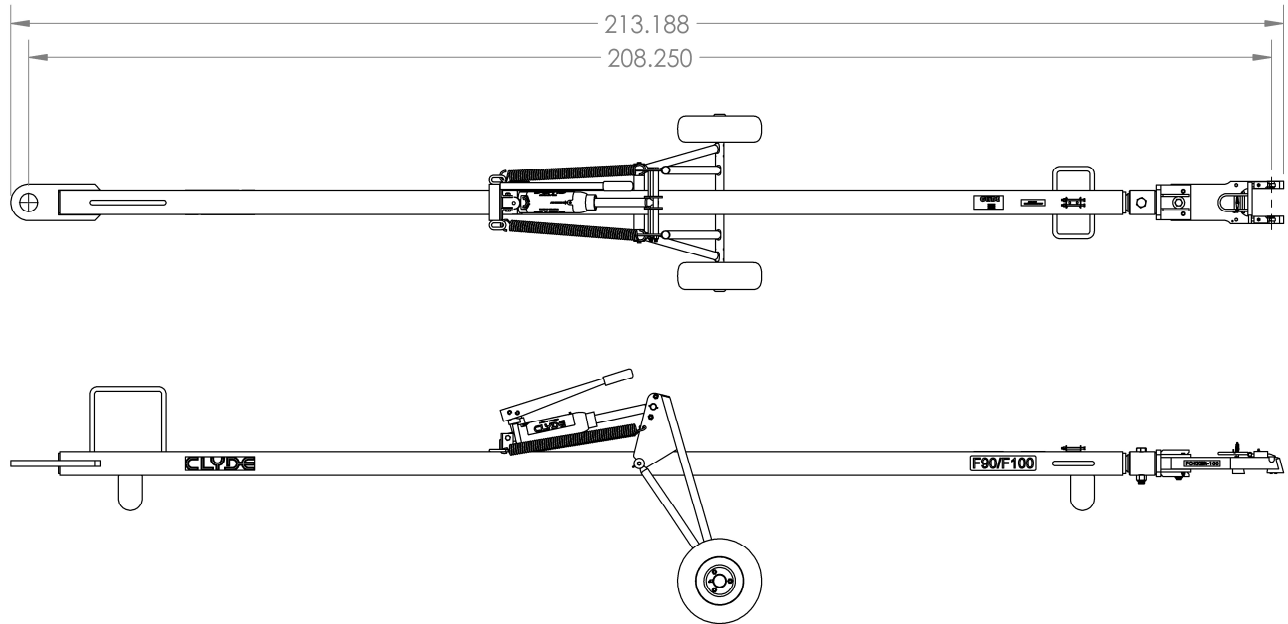

## Shipping Information

- Shipping Dimensions:
  - Weight - 410 lbs
  - Length - 204"
  - Width - 29"
  - Height - 24"
- Crated Dimensions
  - Weight - 775 lbs
  - Length - 217"
  - Width - 26"
  - Height - 27"

**CLYDE**

Clyde Machines  
P.O. Box 194  
1150 Hwy 55 N.  
Glenwood, MN 56334 USA  
(320) 634-4504  
(320) 634-4506 Fax

[www.clydemachines.com](http://www.clydemachines.com)