



15F2342

B747 Towbar

(all series)



Building Quality Ground Support Products Since 1961

- 8" OD x 8' High strength steel tube
- Safety Lock system to avoid separation from aircraft
- Fully retractable hydraulic running gear for adjustable height
- Durable powder coat finish
- Quality shear bolts for aircraft protection
- Extra set of shear bolts included
- Pneumatic tires

CLYDE

Clyde Machines
P.O. Box 194
1150 Hwy 55 N.
Glenwood, MN 56334 USA
(320) 634-4504
(320) 634-4506 Fax

www.clydemachines.com

15F2342

747 Towbar

(all series)

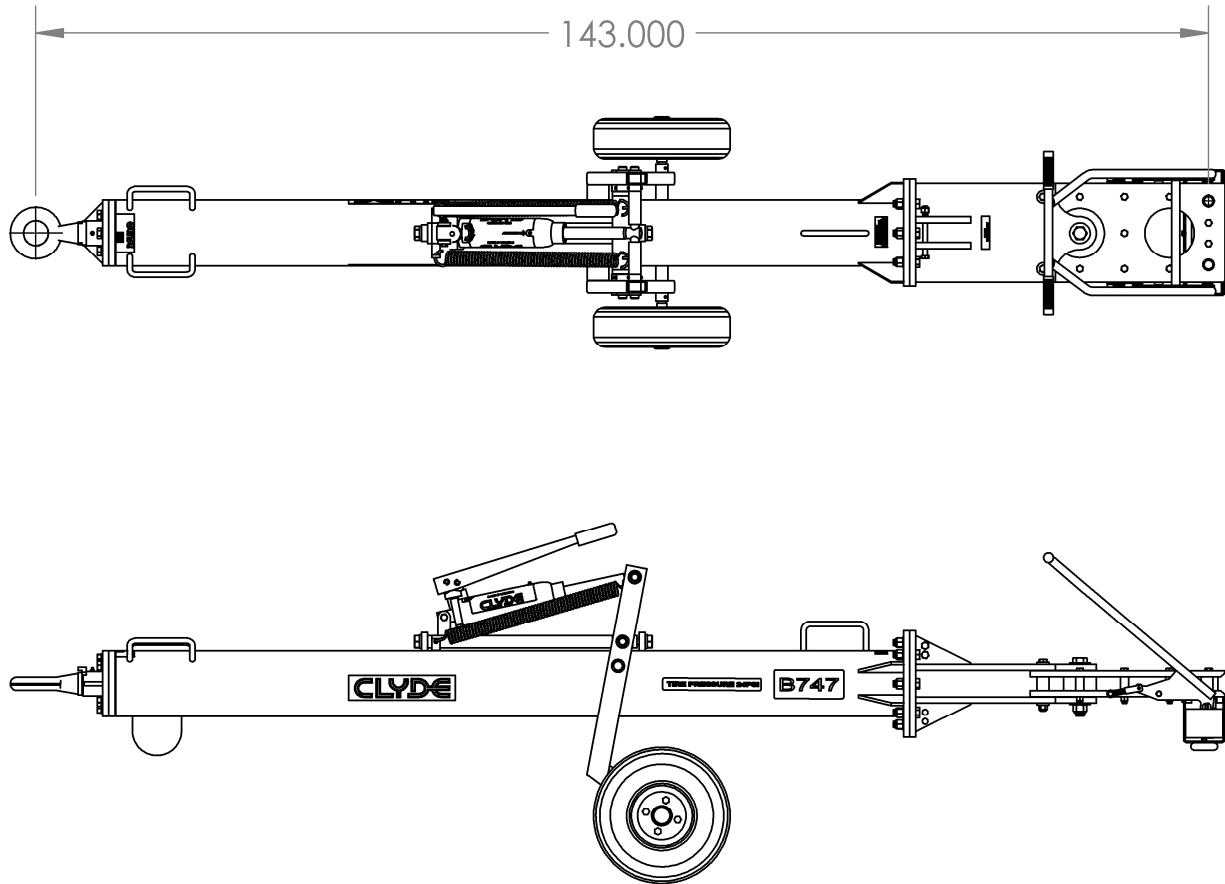

Shipping Information

- Shipping Dimensions:
 - Weight - 680 lbs
 - Length - 150"
 - Width - 25"
 - Height - 29"
- Crated Dimensions:
 - Weight - 930 lbs
 - Length - 152"
 - Width - 26"
 - Height - 34"

CLYDE

Clyde Machines
P.O. Box 194
1150 Hwy 55 N.
Glenwood, MN 56334 USA
(320) 634-4504
(320) 634-4506 Fax

www.clydemachines.com