



15F3092

# Maintenance Stand



## Building Quality Ground Support Products Since 1961

- Non-slip self-cleaning steps and platform floor
- 500 lb platform capacity
- Heavy-duty caster and 16" dia. Solid tires make it easy to move from job-to-job
- Single lever stabilizer/brake
- Upper platform railings can be lifted out and stored below
- Mid platform railings can be easily swung down and out of the way
- Base, stairs, and platform stay parallel at any height position
- All-steel, welded construction
- Platform Heights are: 57", 75", and 86"
- OSHA compliant
- Epoxy powder coat per customer spec

# CLYDE

**Clyde Machines**  
P.O. Box 194  
1150 Hwy 55 N.  
Glenwood, MN 56334 USA  
(320) 634-4504  
(320) 634-4506 Fax

[www.clydemachines.com](http://www.clydemachines.com)

**15F3092**

# Maintenance Stand

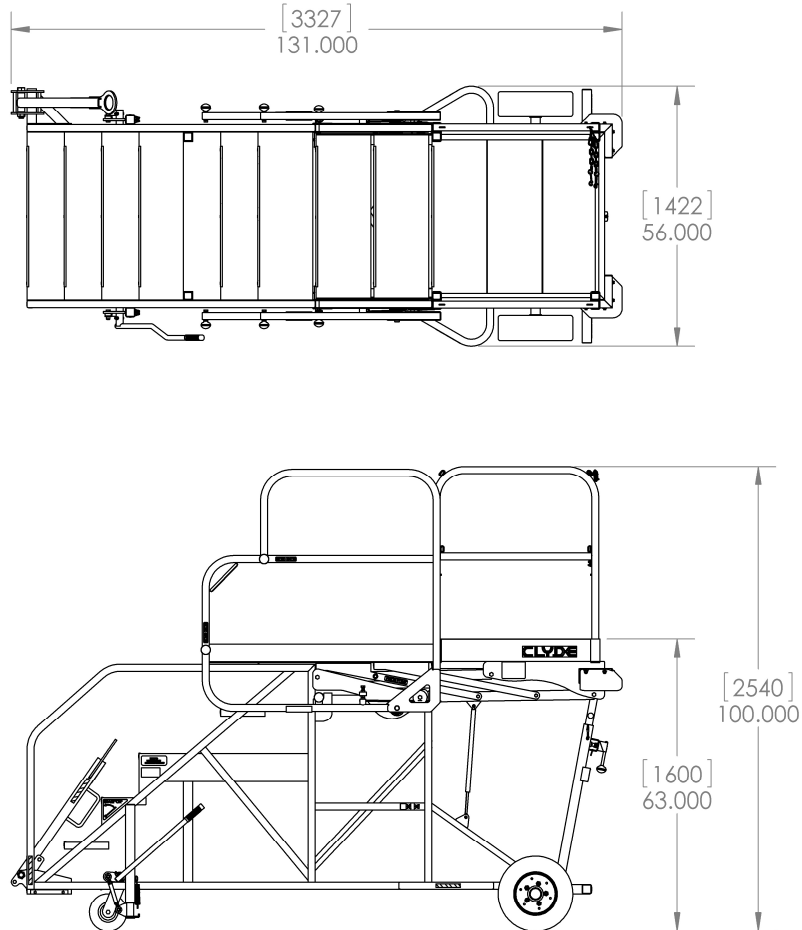

## Shipping Information

- Capacity - 500 lbs
- Platform Height - 57", 75", 86"
- Weight of stand - 890 lbs
- Shipping dimensions
  - Width - 56"
  - Length - 11'
  - Height - 100"

**CLYDE**

**Clyde Machines**  
P.O. Box 194  
1150 Hwy 55 N.  
Glenwood, MN 56334 USA  
(320) 634-4504  
(320) 634-4506 Fax

[www.clydemachines.com](http://www.clydemachines.com)