



15F3166

# B757 Towbar



Building Quality Ground Support Products Since 1961

- 8" x 15' high strength aluminum tube
- Fully retractable hydraulic running gear for adjustable height
- Safety lock system to avoid separation from aircraft
- Durable powder coat paint
- Quality shear bolts for aircraft protection
- Extra set of shear bolts included
- Solid tires
- Optional pneumatic or foam filled tires

# CLYDE

Clyde Machines  
P.O. Box 194  
1150 Hwy 55 N.  
Glenwood, MN 56334 USA  
(320) 634-4504  
(320) 634-4506 Fax

[www.clydemachines.com](http://www.clydemachines.com)

**15F3166**

# B757 Towbar

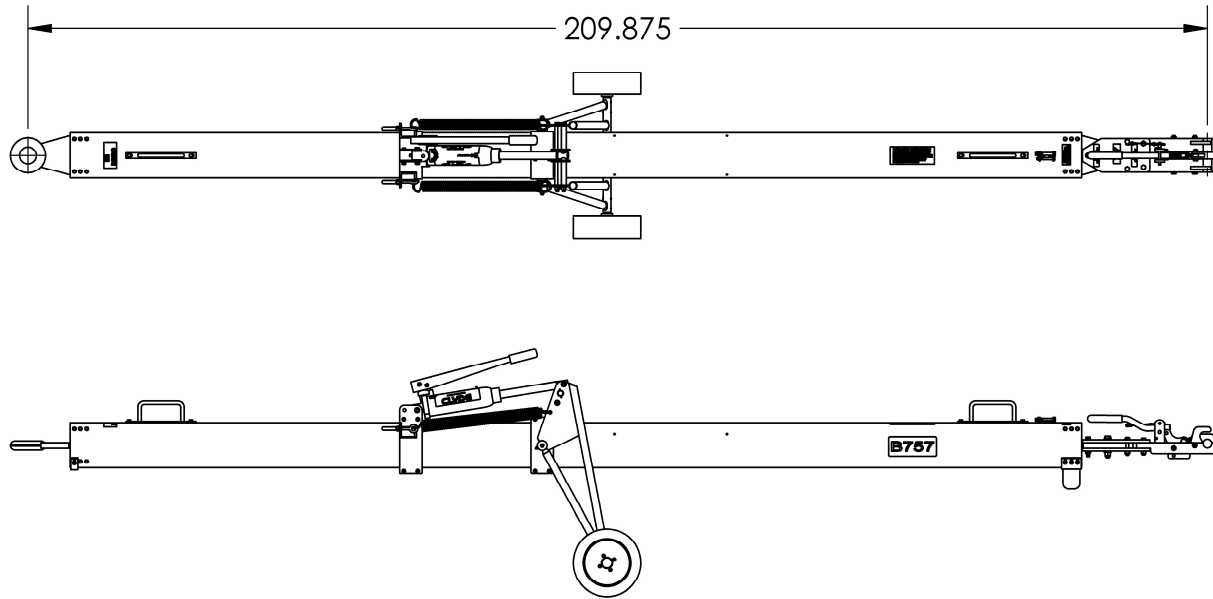

## Shipping Information

### Shipping Weight

- 350 lbs.

### Crated Weight

- 730 lbs.

### Shipping Dimensions

- Length — 212"
- Width — 29"
- Height — 25"

### Crated Dimensions

- Length— 217"
- Width— 26"
- Height— 27"

# CLYDE

**Clyde Machines**  
P.O. Box 194  
1150 Hwy 55 N.  
Glenwood, MN 56334 USA  
(320) 634-4504  
(320) 634-4506 Fax

[www.clydemachines.com](http://www.clydemachines.com)